

PRELIMINARY (FOR INFORMATION ONLY)

ABB is not liable for information contained herein which contradicts local codes, permitting requirements, and other requirements. ABB highly recommends a qualified design engineering firm to be responsible for the charging installation to ensure all of these requirements are met. Use this brief in conjunction with ABB Terra HP Install Manual.

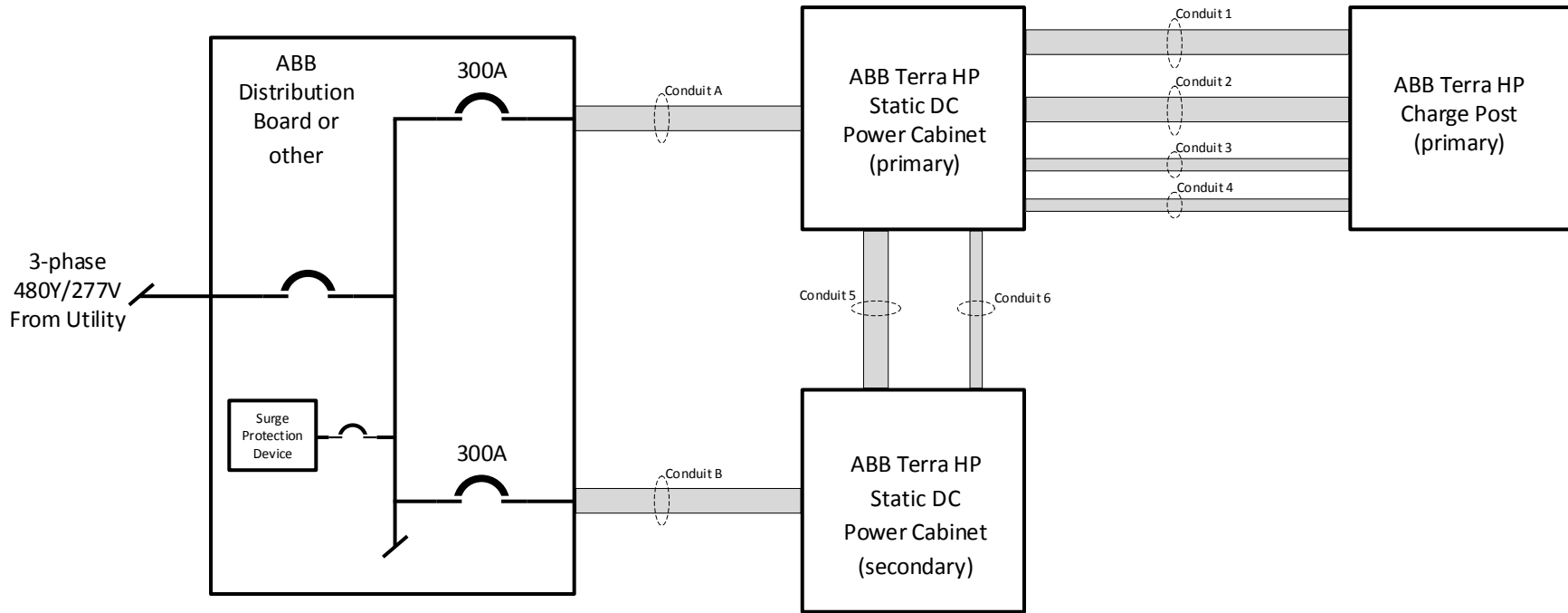

CONDUIT IDs	FUNCTION OF INTERNAL CABLES	CABLE SELECTION	COMMENTS
A, B	AC UTILITY POWER	(3) 350 MCM TO 500 MCM (CU, 75°C, 600V) + (1) #2 (CU, 75°C, 600V, EGC)	IF UPSTREAM OCPD RATED 300A
1, 2	DC POWER + PE	(2) 262.6 KCMIL (CU, 75°C, DLO, 2KV) + (1) #2 (CU, 75°C, 600V, EGC)	UP TO 500A FROM EACH CAB TO POST
3	DC GUARD	(1) CABLE THAT HAS (2) TWISTED PAIR OF #18 (SHIELDED, CU, 600V)	
	INTERLOCK		
	FIBER CAN BUS	(1) MULTIMODE FIBER (OM3, 4 STRANDS)	ST CONNECTORS ON ALL ENDS
4	CONTROL 3 ϕ , 480VAC INPUT	(1) CABLE THAT HAS (3) #12 (CU, 75°C, 600V) + (1) #12 (CU, 75°C, 600V, EGC)	UPSTREAM OCPD RATED 16A
5	DC POWER	(2) SETS OF (2) 262.2 KCMIL (CU, 75°C, DLO, 2KV) + (1) #2 (CU, 75°C, 600V, EGC)	UP TO 375A BETWEEN CABINETS
6	DC GUARD	(1) CABLE THAT HAS (2) TWISTED PAIR OF #18 (SHIELDED, CU, 600V)	
	INTERLOCK		
	COPPER CAN BUS	(1) CABLE THAT HAS (1) TWISTED PAIR (SHIELDED, SAE J1939-11, CU, 600V)	

Notes:

1. If applicable, please consider how NEC Article 625.43 would be met. Please consult with ABB to learn more about specific ABB electrical distribution system solutions for EV charging stations.
2. Customer must verify the recommended 300A circuit breaker size, conduit layout, and cable and compression terminal selections comply with local codes and regulations and engineering best practices. This includes verifying the cables of different voltage categories are routed in a proper manner depending on the foundation design and to ensure that the system design meets the voltage drop requirements required for the EV charging system performance. For proper conduit sizing, refer to NEC Chapter 9 and Annex C.
3. The maximum distance permissible between the each power cabinet and dispenser is 200 feet or 60m.



TITLE					
Terra HP 350kW Static – Conduits and Cables in USA					
REV	DATE	BY	DESCRIPTION	DRAWING	REV
-	2020-12-10	-	PRELIMINARY FOR DISCUSSION		A
-	-	-	-		
-	-	-	-		