

Product must meet current standard requirements Category A or B as indicated in PI  
 General tolerances according to ISO 2768  
 Supplier's inspection must comply with procedure DIN 69020  
 Dimensions specified in mm are critical dimensions and require inspection. Dimensional  
 control must be carried out on the finished product.  
 Parts must be packaged to prevent damage in shipment and handling in use.  
 All dimensions are in millimeters unless otherwise specified.

Do not wrap rear panel

Do not wrap zones marked with \*

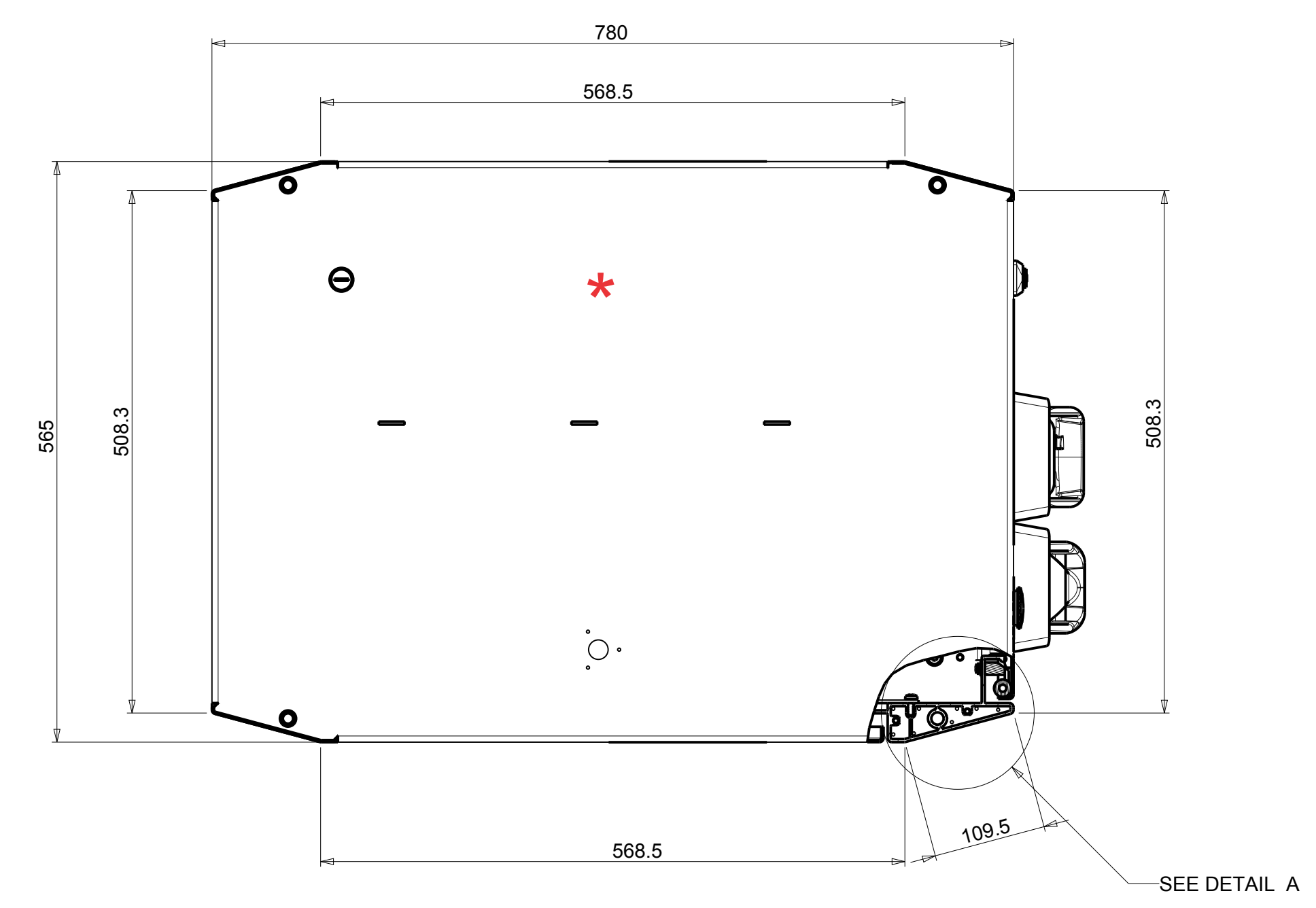
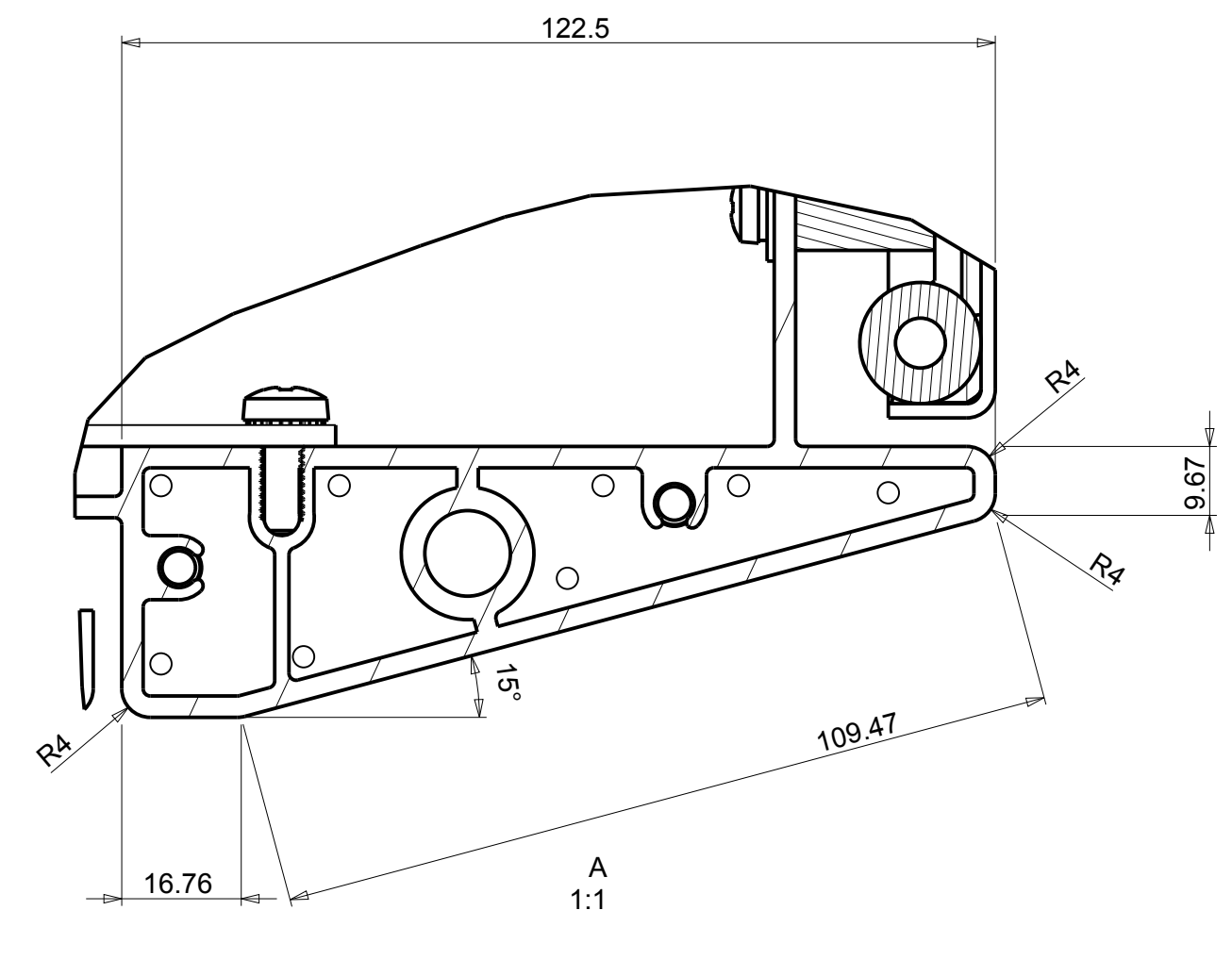
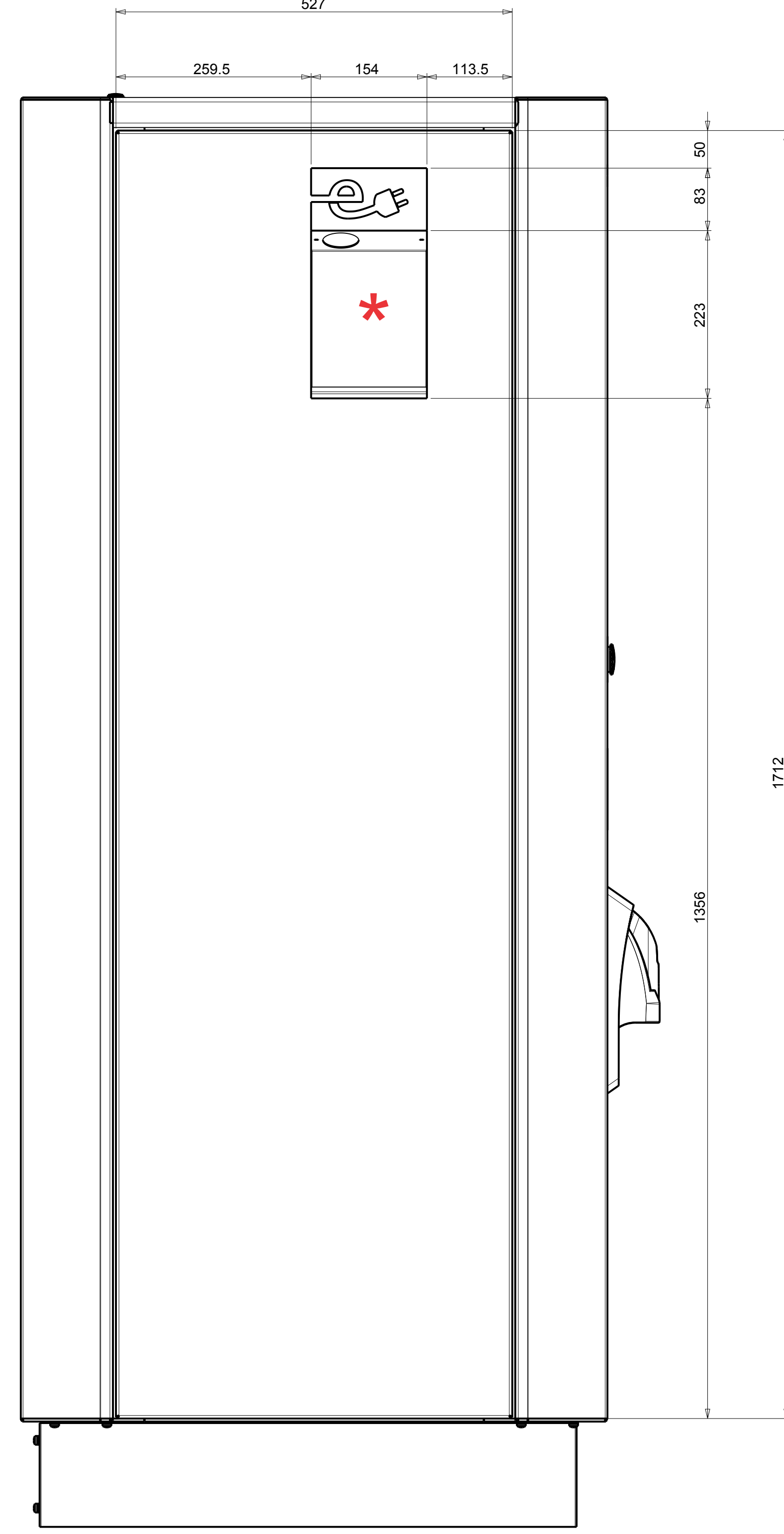
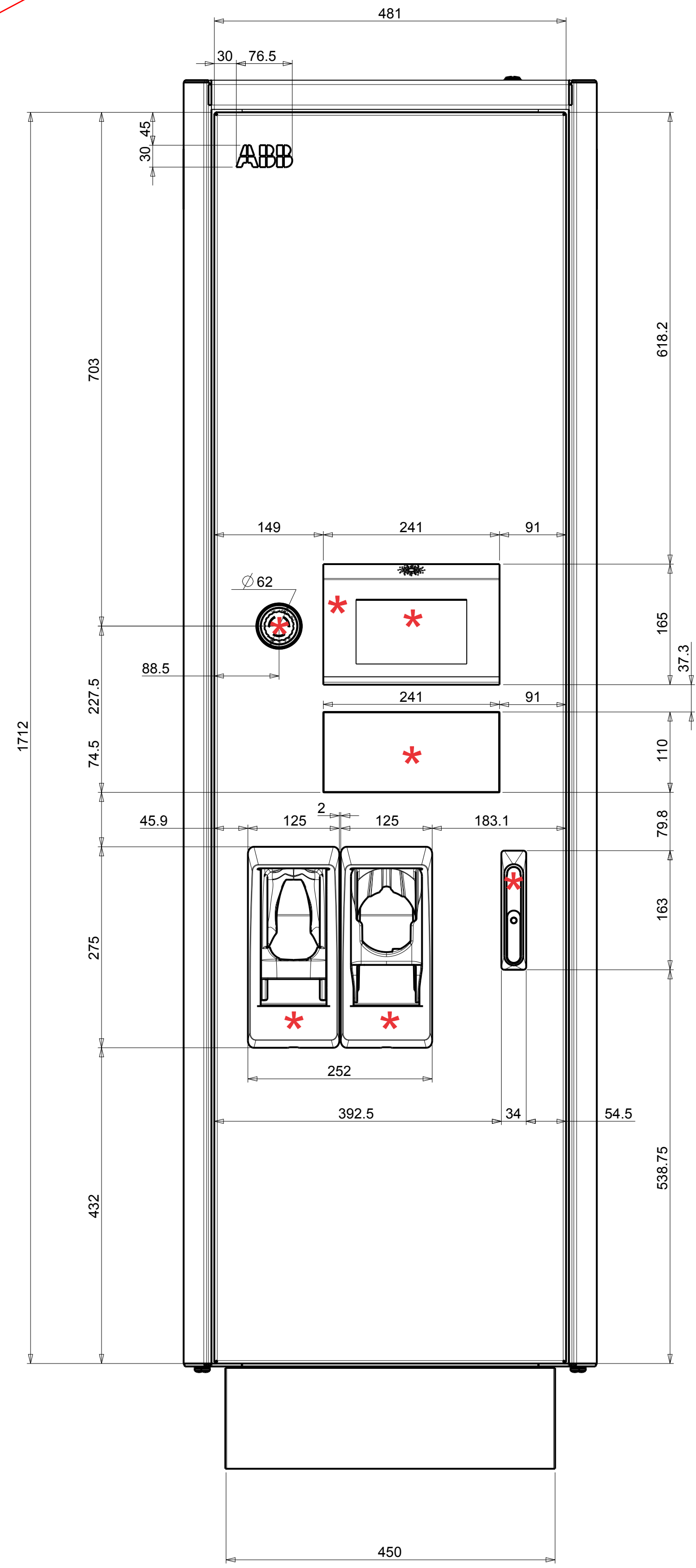
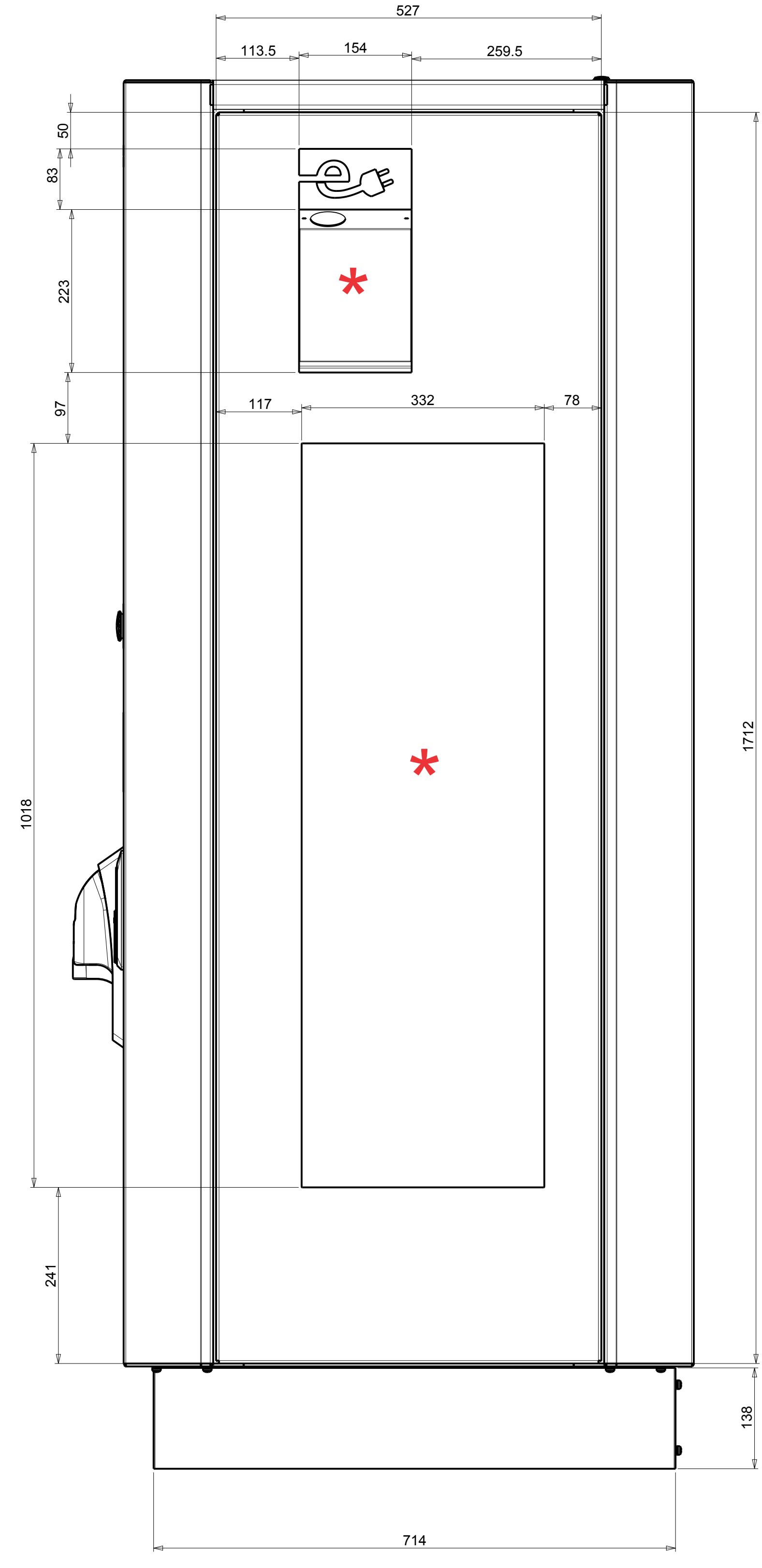

Version	Revision	Description	Designer	Date	ECO	
0	AA	ITEM CREATION		16/05/18	C80313	
All material used, and finished product, must meet the requirements of the current RoHS directive of the European Union.						
Dimensions with general tolerances according to ISO 2768						
Precision	0.5-3	3-6	6-30	30-120	120-400	400-1000
Fine	±0.05	±0.05	±0.1	±0.15	±0.2	±0.3
Medium	±0.1	±0.1	±0.2	±0.3	±0.5	±0.8
Coarse	±0.2	±0.3	±0.5	±0.8	±1.2	±2
Material	SEE NOTES		Treatment	SEE NOTES		Weight <b>208.773 kg</b>
Issued: 16/05/18 C80313/1 Modified: _____ Mech. Eng. approved: _____ Elec. Eng. approved: _____ Mfg. approved: _____						
<b>TX4 CJ-UL; GLOBAL VIEW FOR FOILING</b>						
Size A0 Scale 1:5 Unit (mm) 1/1		Drawing No. URL_V2N13.0		Revision 01		